



Overview

Floor Protector allows for quick, efficient, and cost-effective installation of Fastlane optical turnstiles without damaging the floor of the building.

Applications

Floor Protector is ideal for applications where the flooring materials used (such as marble, tile, granite, etc.) in the floor restrict drilling and cabling or where any such work would be prohibited. Additionally, the system is useful for temporary installations where the tenants of a building are not allowed to affect the infrastructure of the building.

Accessibility

Floor Protector meets ADA specifications, and the angle and height of the ramp ensure ADA compliance and wheelchair friendly access.

EXAMPLES OF FLOOR PROTECTORS

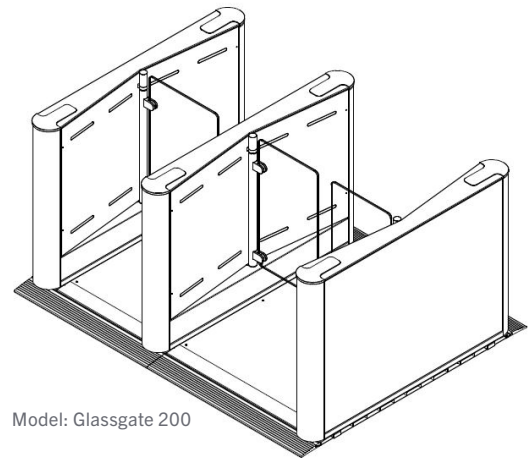

Model: Glassgate 200

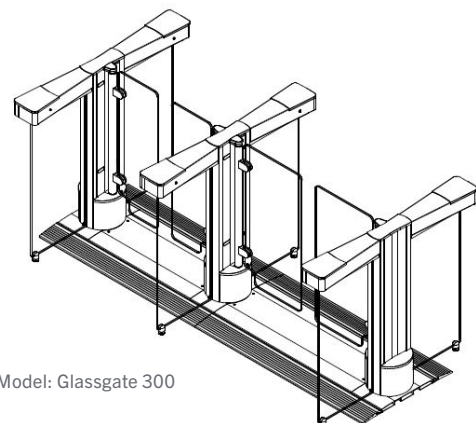

Model: Glassgate 300

Accessories

Fastlane® Floor Protector

Supplemental Floor Protection System

Fastlane Floor Protector is a modular system designed to enable usage of Fastlane turnstiles without the need for drilling fixing bolts into the floor or running a conduit for cables under the floor between pedestals.

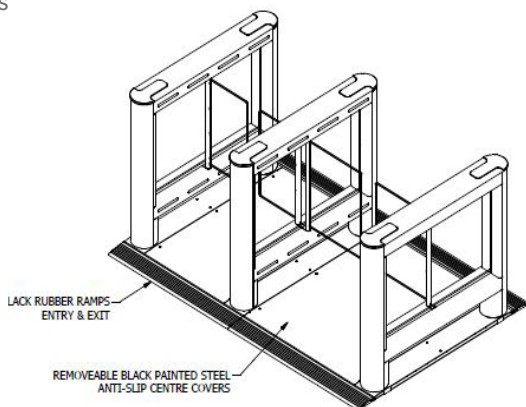

Materials

- Mild Steel

The Fastlane® Floor Protector System is a series of metal components that are designed to allow the installation of Fastlane® turnstiles in an area where cables cannot be run under the floor.

The Floor Protector can also be used for temporary installations and enables pedestals to be installed quickly and cost effectively, without drilling or otherwise damaging the floor on which they stand.

Each component part of the Floor Protector is clamped to a pair of Unistrut® Single Channels.

TECHNICAL SPECIFICATIONS

Base	Lane width	Material
<ul style="list-style-type: none"> ■ Height: .79" (20 mm) ■ Slope Angle: 1 in 12 ■ Length: vary based on model chosen example 38" (967 mm) for Fastlane Plus ■ Black rubber ramps extend 8.75" beyond model length upon entry and exit 	<ul style="list-style-type: none"> ■ Std. lane: 26" (660 mm) ■ ADA lane: 36" (914 mm) 	<ul style="list-style-type: none"> ■ Mild Steel
Cable Tray dims	Color	
<ul style="list-style-type: none"> ■ 2" x .6" (50 mm x 15 mm) 	<ul style="list-style-type: none"> ■ Black 	

* Due to continuous improvements, specifications are subject to change without prior notice.

DETAILS

Mechanical Layout Drawings

(Floor Protector for Fastlane Plus 400 MA)

Floor Protector dimensions may vary based on Fastlane turnstile model.

