

**MATERIAL SPECIFICATIONS**

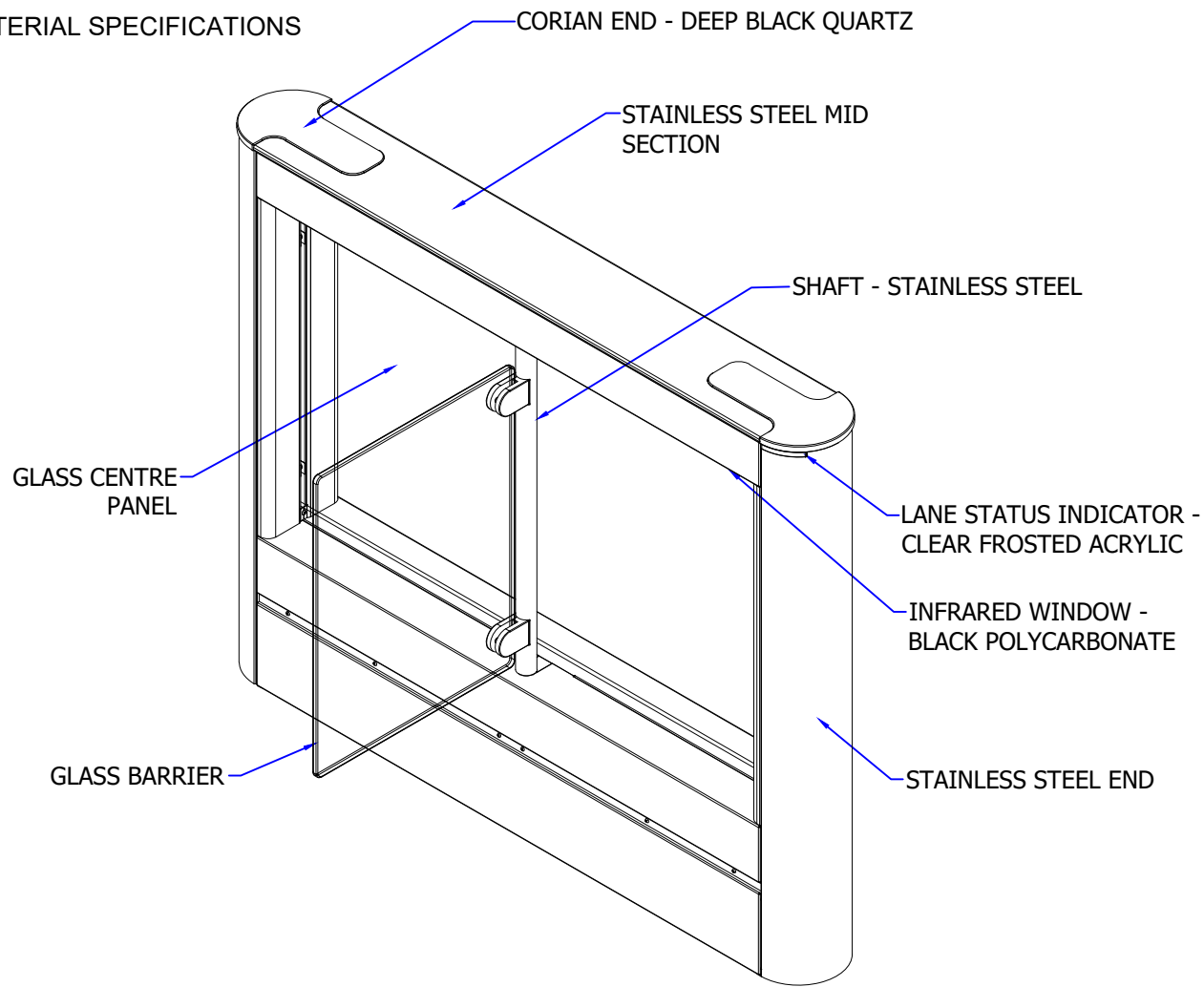

ALL GLASS IS TOUGHENED - EN12150  
 ALL STAINLESS STEEL IS 304, 240 GRIT (SATIN No. 4), HORIZONTAL GRAIN  
 DECORATIVE TOP - STAINLESS STEEL AND CORIAN HAS 4mm OVERHANG

**READER MOUNTING OPTIONS AND LOGO DETAILS**

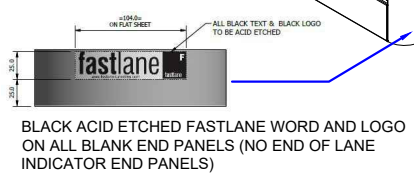
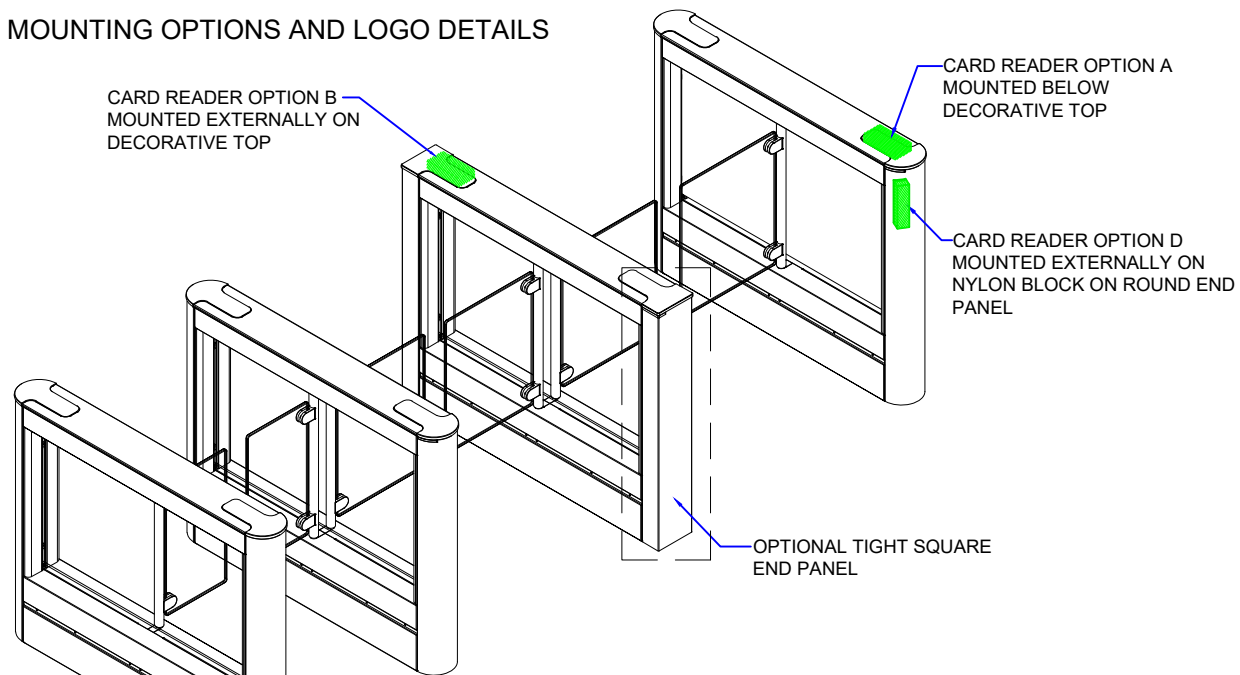

**LANE LAYOUT & GENERAL DIMENSIONS**

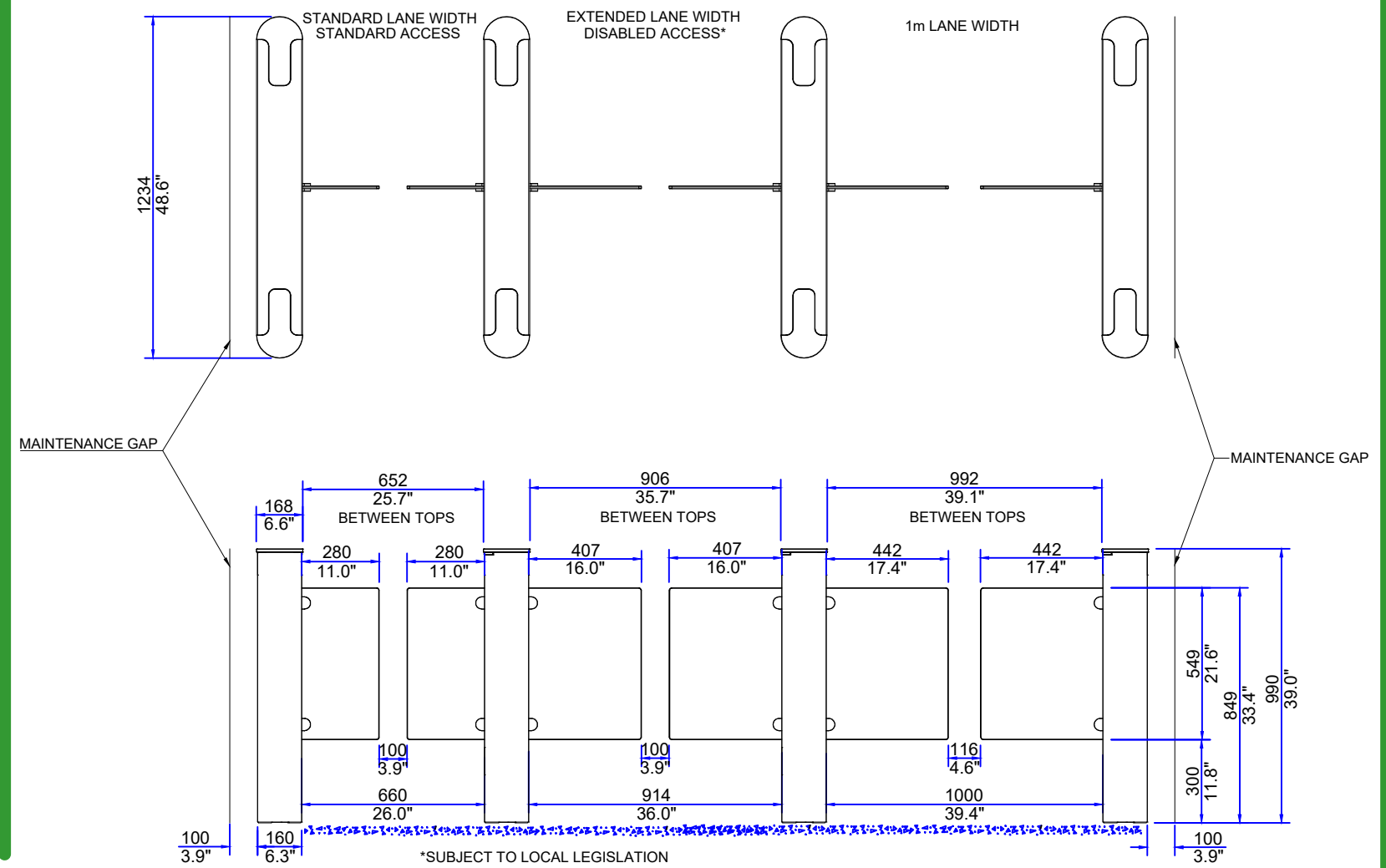

**PEDESTAL FOOTPRINT**

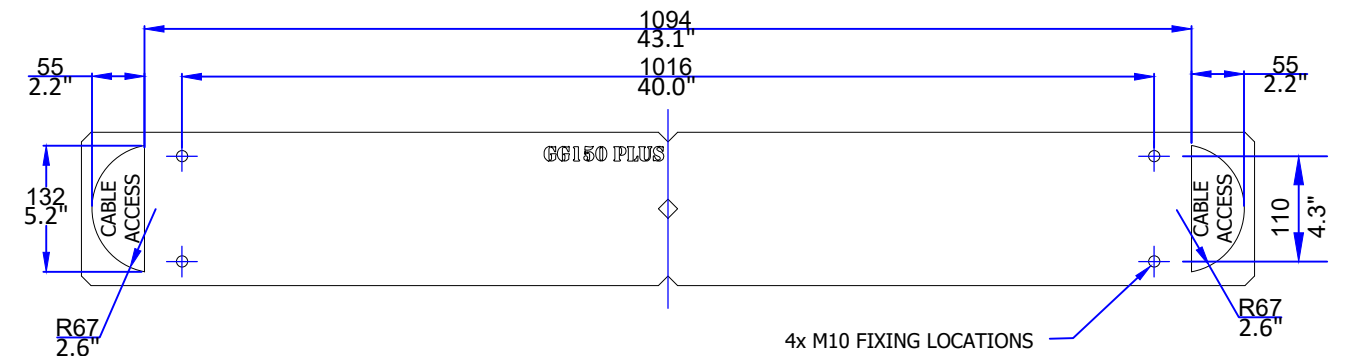

**PRODUCT: GLASSGATE 150 PLUS**

**TITLE: GENERAL INFORMATION**

**DRAWING No: GG150PLUS\_A2**

FOR SALES INFORMATION ONLY-SUBJECT TO CHANGE  
 ALL DIMENSIONS +/- 2MM

This document is the copyright of Integrated Design Ltd

