

GENERAL DIMENSIONS

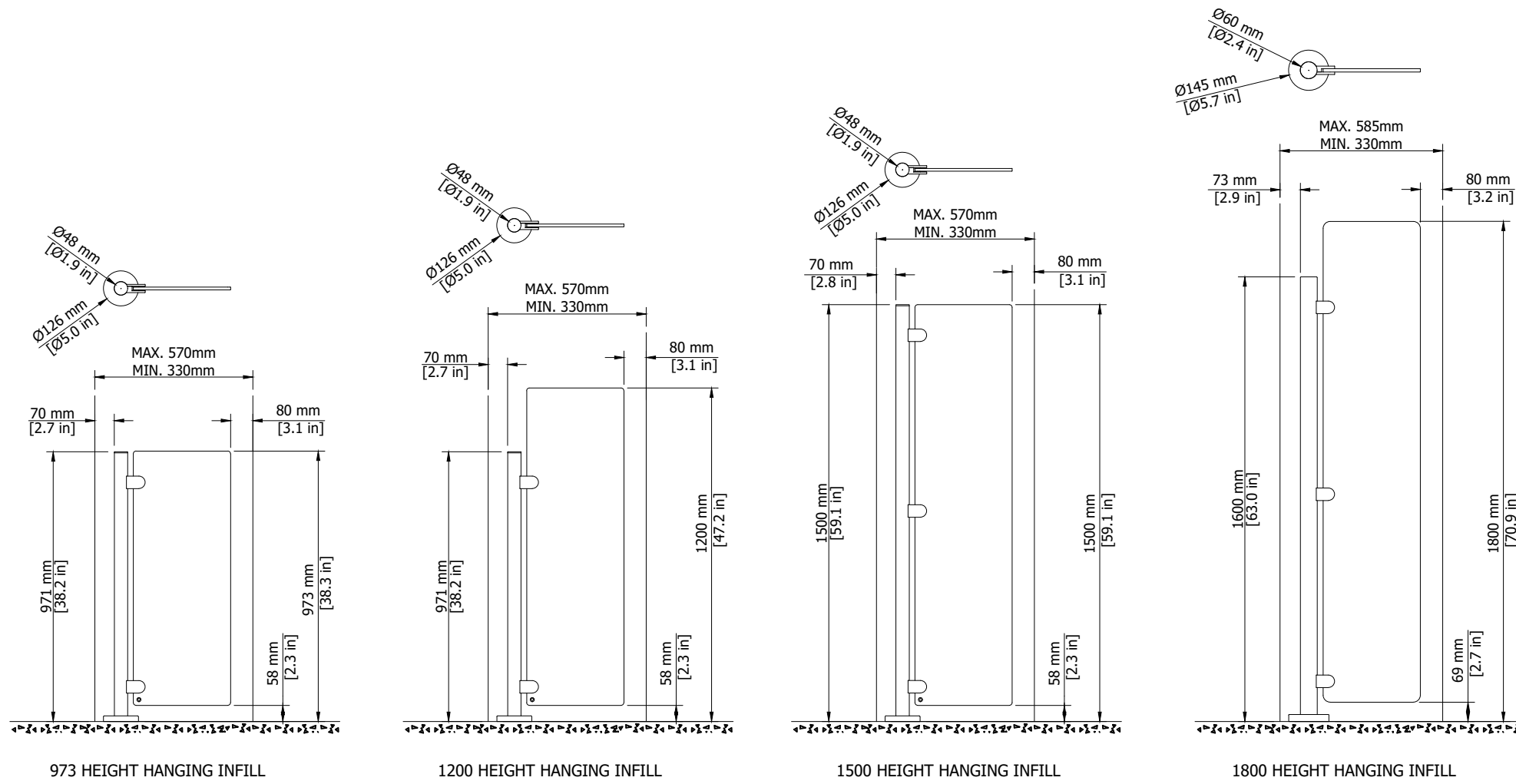

GENERAL MATERIAL SPECIFICATIONS

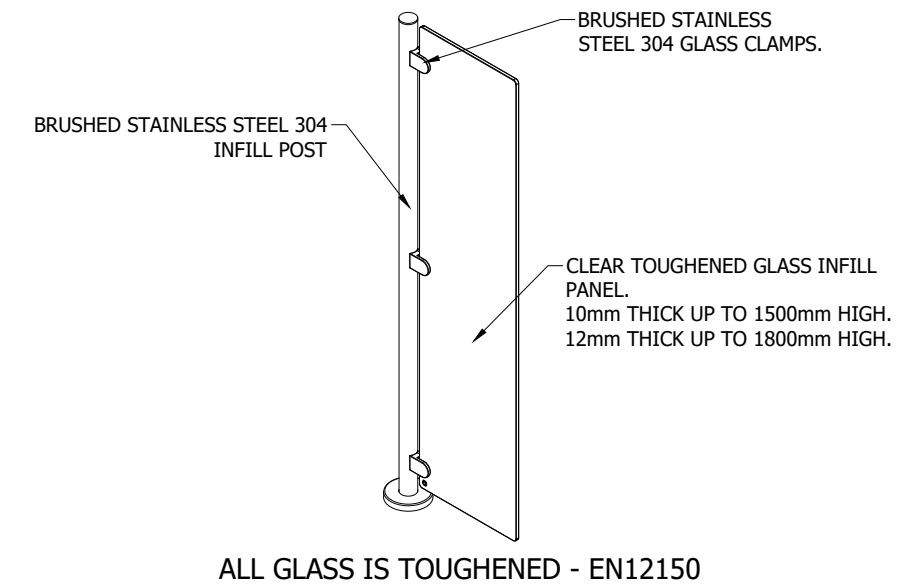

FIXING POSITIONS

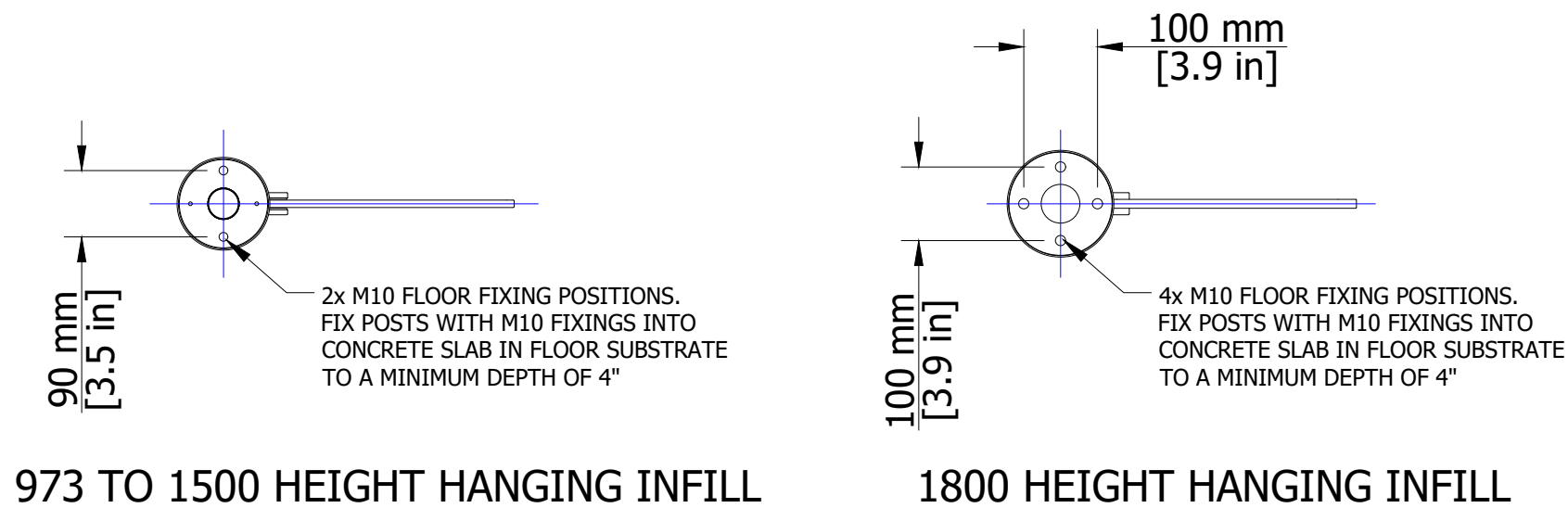

PRODUCT: HANGING INFILL

TITLE: GENERAL INFORMATION

DRAWING No: HANGINGINFILL_A1

FOR SALES INFORMATION ONLY-SUBJECT TO CHANGE
ALL DIMENSIONS NOMINAL

This document is the copyright of Integrated Design Ltd

