

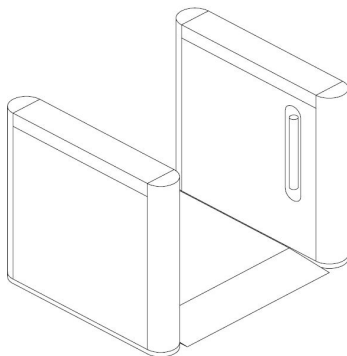

Supplemental Floor Protection System

Fastlane Floor Protector is a modular system designed to enable usage of Fastlane turnstiles without the need for drilling fixing bolts into the floor or running a conduit for cables under the floor between pedestals.

Figure 1



Overview

Floor Protector allows for quick, efficient, and cost-effective installation of Fastlane optical turnstiles without damaging the floor of the building.

Applications

Floor Protector is ideal for applications where the flooring materials used (such as marble, tile, granite, etc.) in the floor restrict drilling and cabling or where any such work would be prohibited. Additionally, the system is useful for temporary installations where the tenants of a building are not allowed to affect the infrastructure of the building.

Accessibility

Floor Protector meets ADA specifications, and the angle and height of the ramp ensure ADA compliance and wheelchair-friendly access.

Technical specifications

Base	
Max Height	.79" (20 mm)
Slope Angle	1 in 12
Lane Width	26" (660 mm) standard 36" (915 mm) disabled
Length	38" (967 mm) for Fastlane Plus Other options for other pedestals
Material	Mild Steel
Cable tray dims	2" x .6" (50 mm x 15 mm)
Color	Black

* Due to continuous improvements, specifications are subject to change without prior notice.

Mechanical Layout Drawings

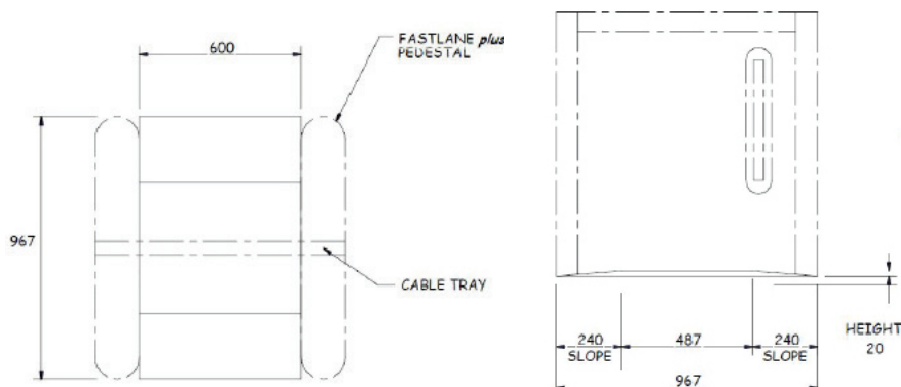

Manufactured by Integrated Design Limited. Fastlane is a registered trademark of IDL, 1995.

