

**MATERIAL SPECIFICATIONS**

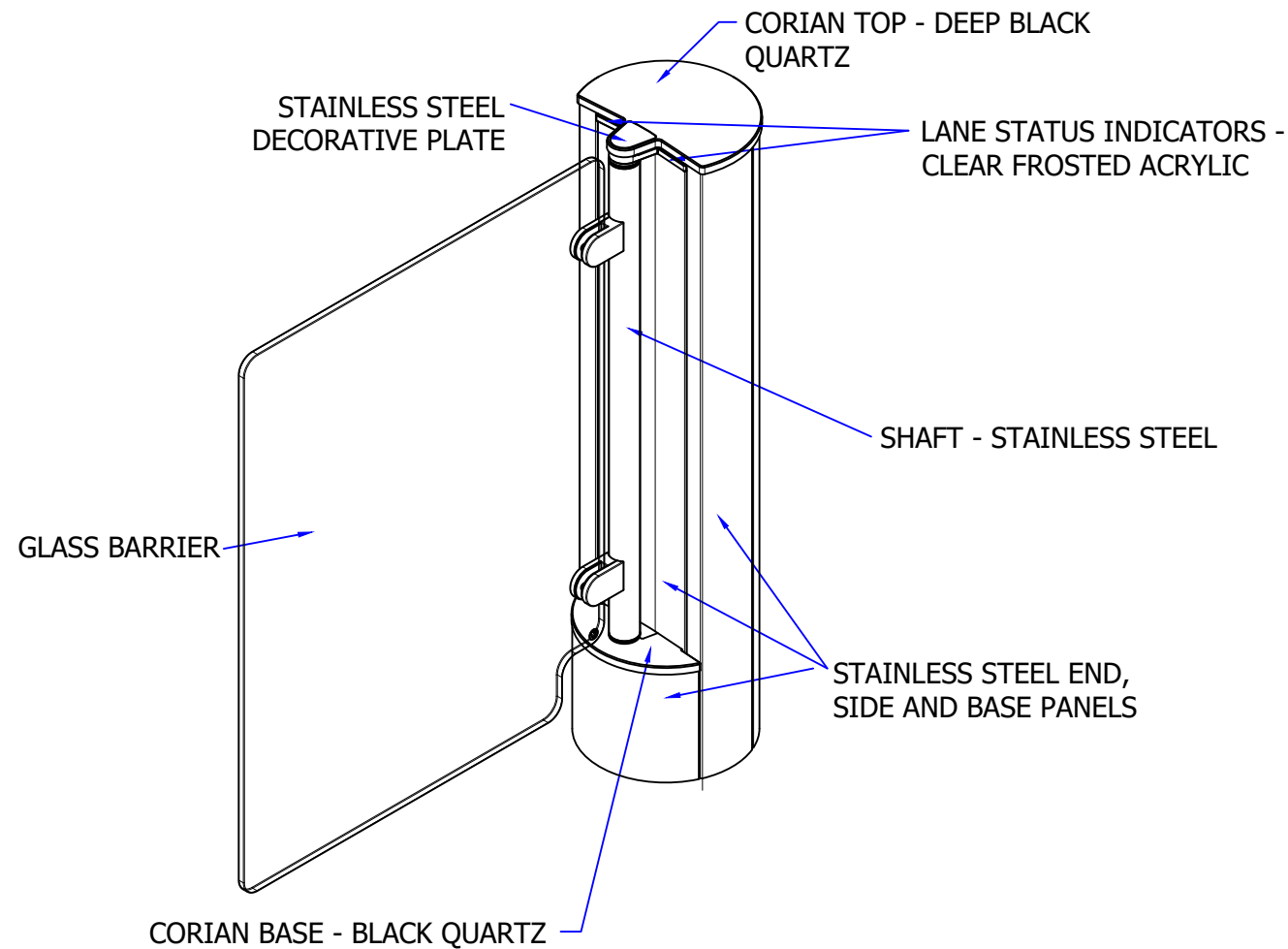

ALL STAINLESS STEEL IS 304, 240 GRIT (SATIN No. 4), HORIZONTAL GRAIN  
 ALL GLASS IS TOUGHENED- EN 12150

**LANE LAYOUT & GENERAL DIMENSIONS**

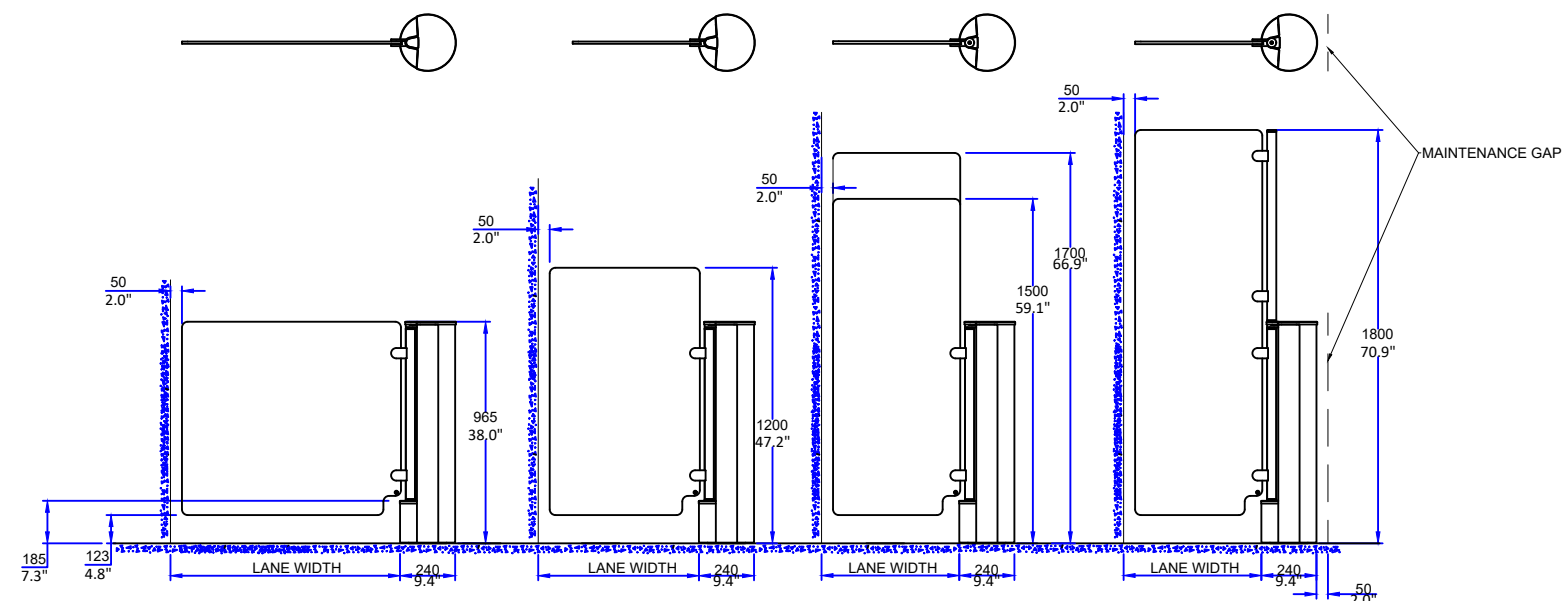

965mm & 1200mm GLASS HEIGHT - 10mm TOUGHENED GLASS  
 1500mm & 1800mm GLASS HEIGHT - TWO PIECES OF 5mm TOUGHENED GLASS WITH 1.5mm LAMINATE FILM IN BETWEEN

LANE WIDTH	HEIGHT OPTIONS				
	1000mm	965mm			
700mm	965mm	1200mm			
600mm	965mm	1200mm	1500mm	1700mm	1800mm

**READER DETAILS**

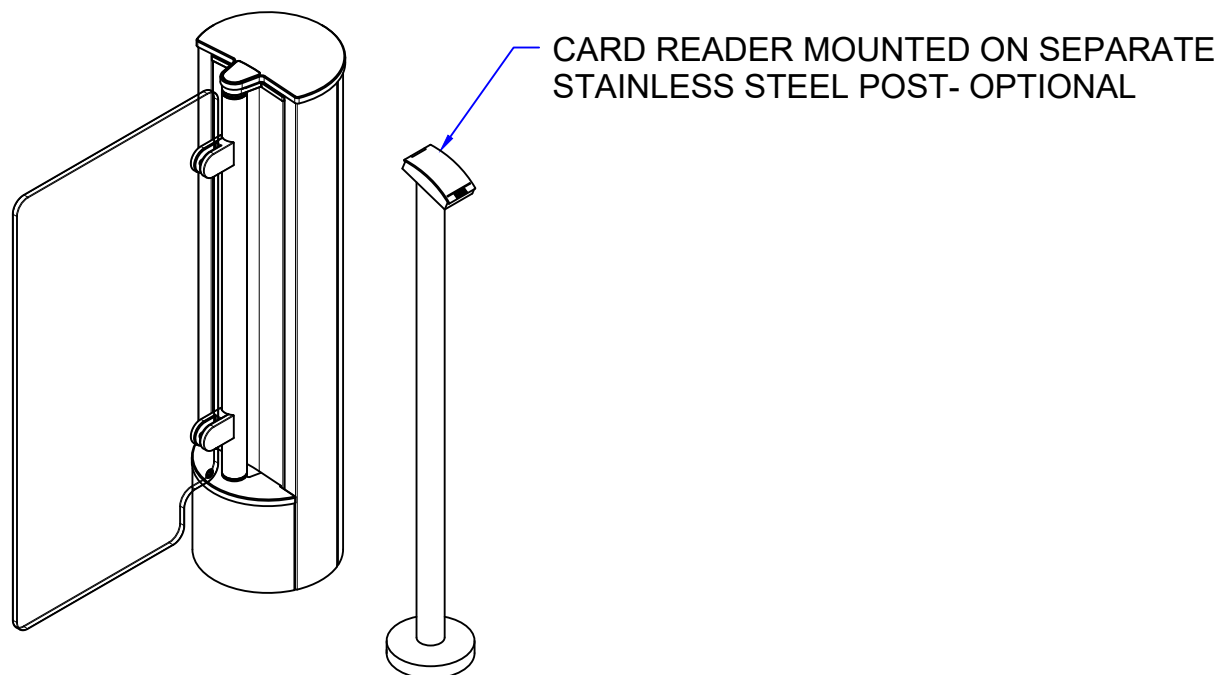

**PEDESTAL FOOTPRINT**

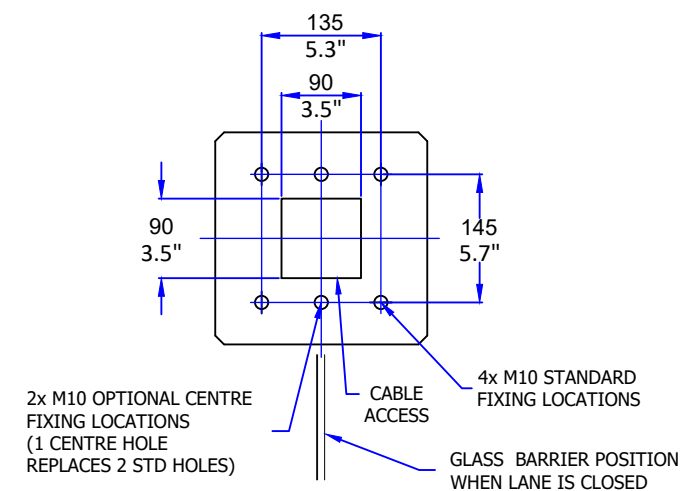

**PRODUCT: PASSGATE 300**

**TITLE: GENERAL INFORMATION**

**DRAWING No: PASSGATE300\_A5**

FOR SALES INFORMATION ONLY-SUBJECT TO CHANGE  
 ALL DIMENSIONS +/- 2MM

This document is the copyright of Integrated Design Ltd

