

MATERIAL SPECIFICATIONS

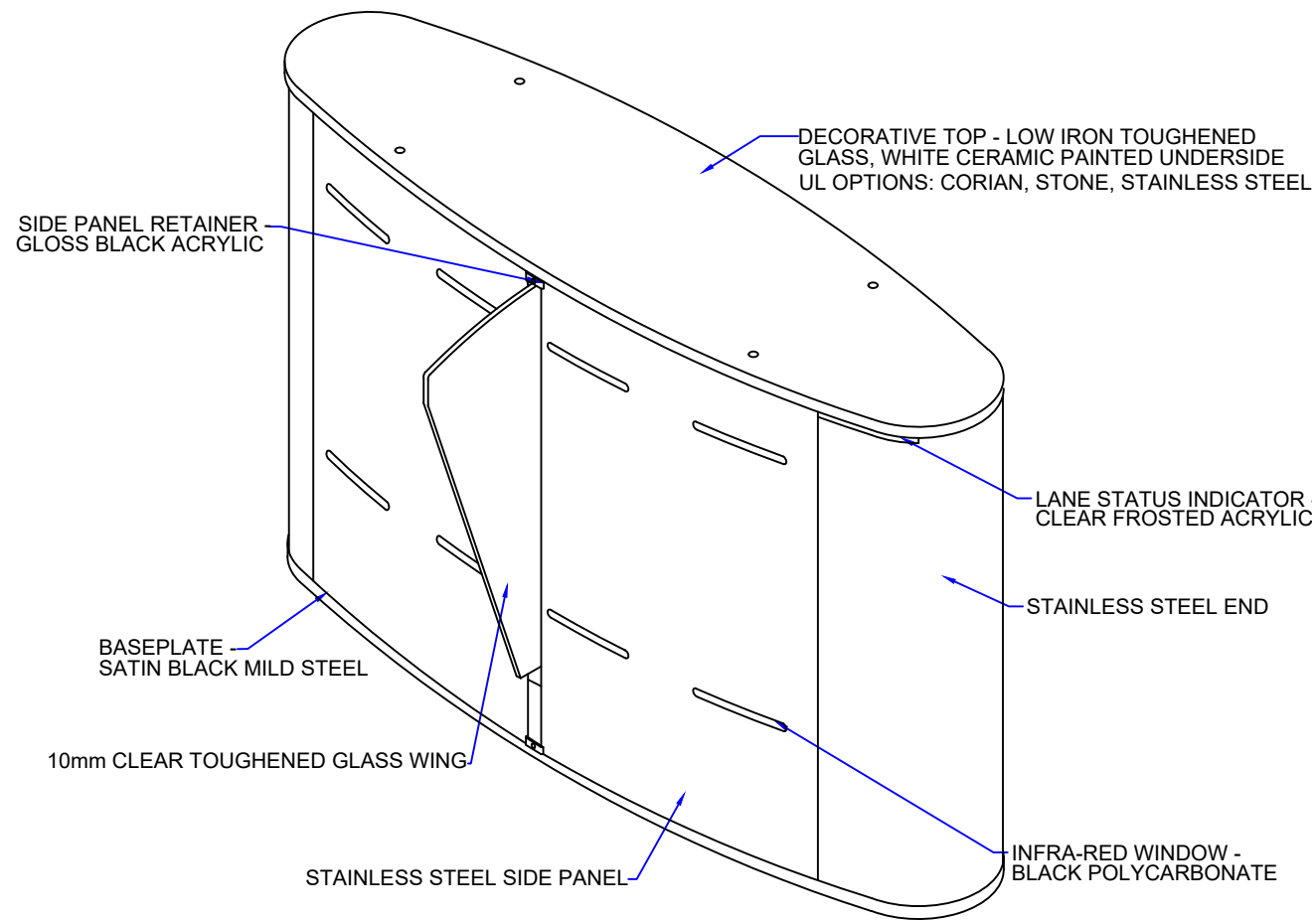

ALL GLASS IS TOUGHENED - EN12150 / ANSI Z97.1
ALL STAINLESS STEEL IS 304, 240 GRIT (SATIN No. 4), HORIZONTAL GRAIN

LANE LAYOUT & GENERAL DIMENSIONS

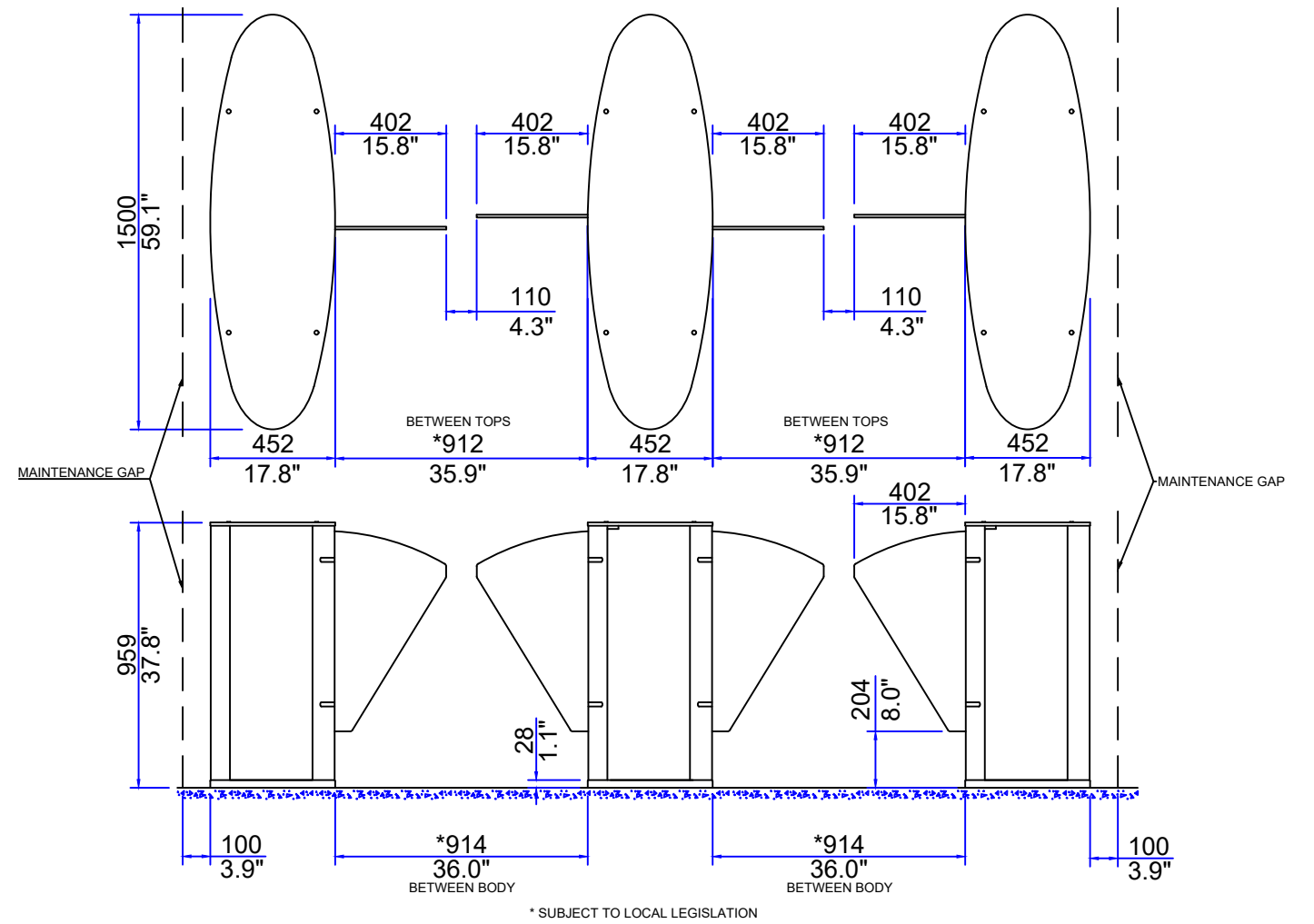

READER MOUNTING OPTIONS

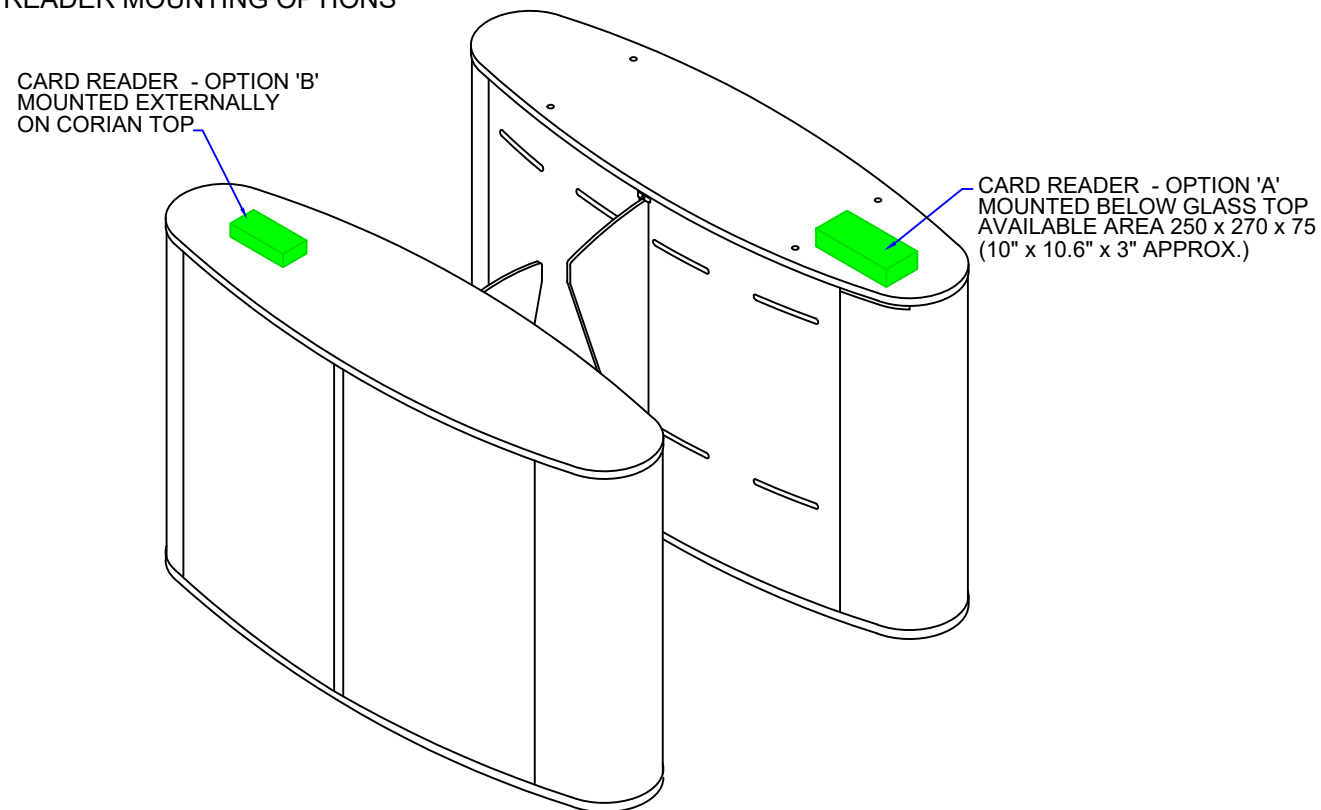

PEDESTAL FOOTPRINT

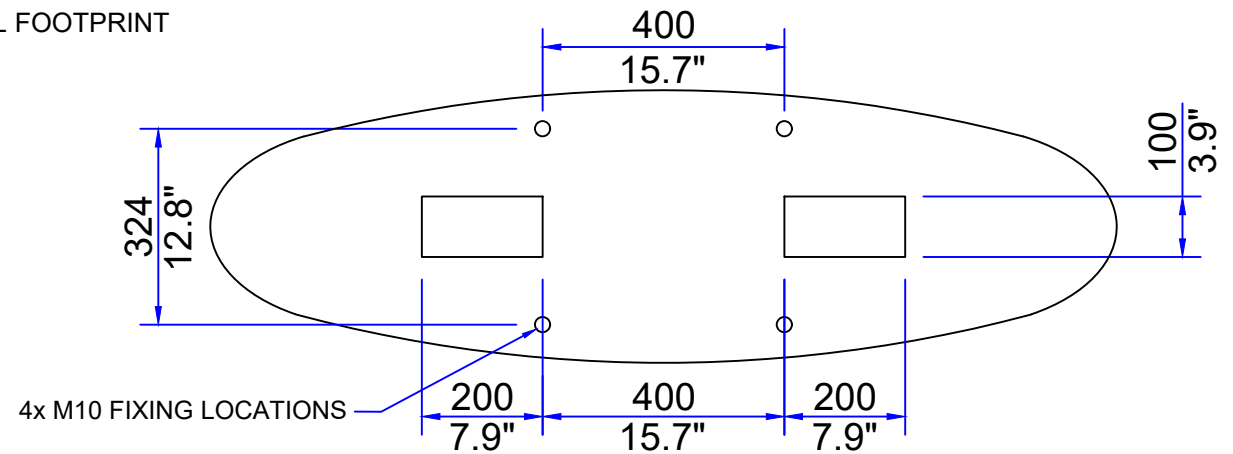

PRODUCT: GLASSWING DDA
TITLE: GENERAL INFORMATION

DRAWING No: GWDDA_A5
FOR SALES INFORMATION ONLY-SUBJECT TO CHANGE
ALL DIMENSIONS +/-2mm
This document is the copyright of Integrated Design LTD

