

**MATERIAL SPECIFICATION**

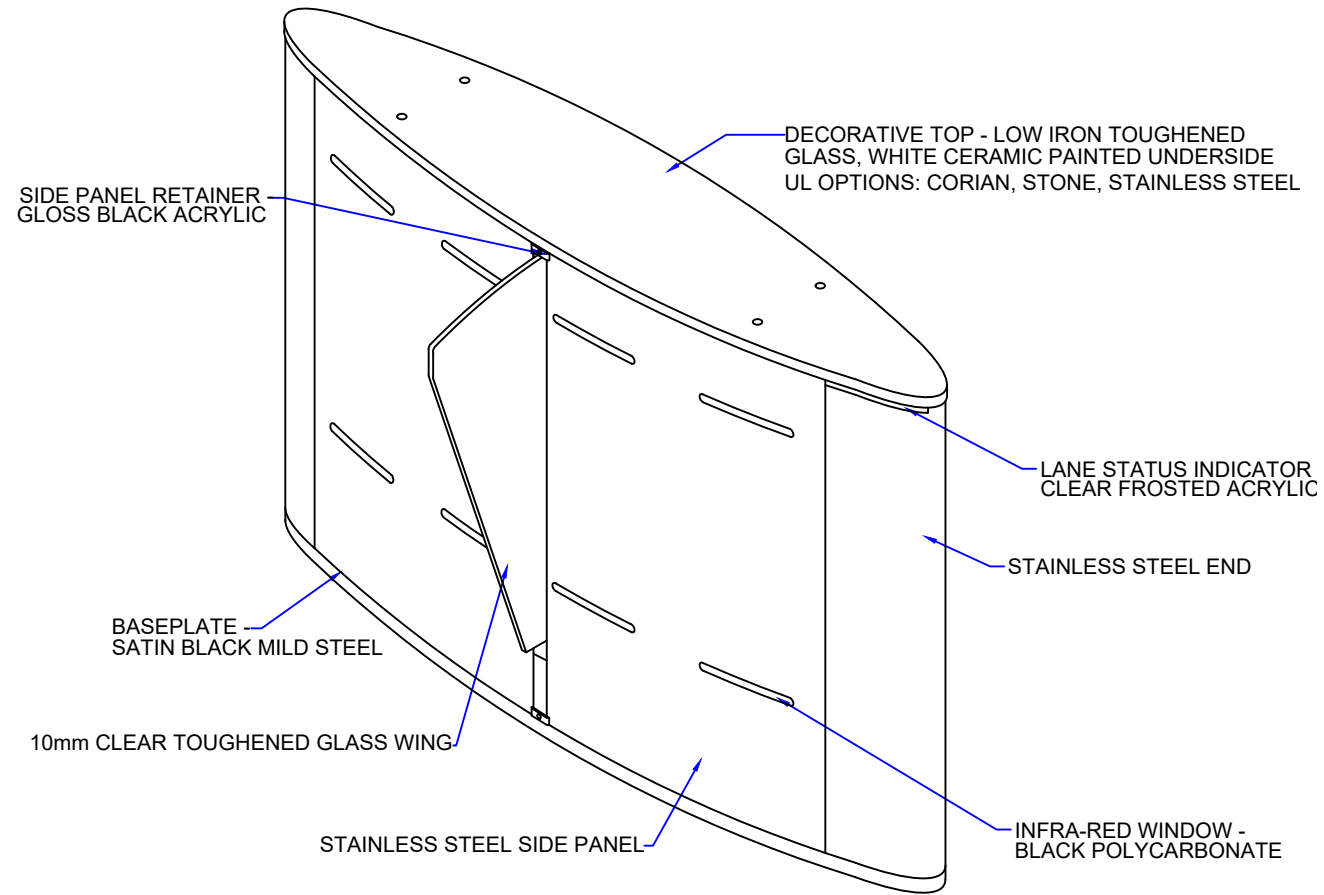

ALL GLASS IS TOUGHENED - EN12150 / ANSI Z97.1  
ALL STAINLESS STEEL IS 304, 240 GRIT (SATIN No. 4), HORIZONTAL GRAIN

**LANE LAYOUT & GENERAL DIMENSIONS**

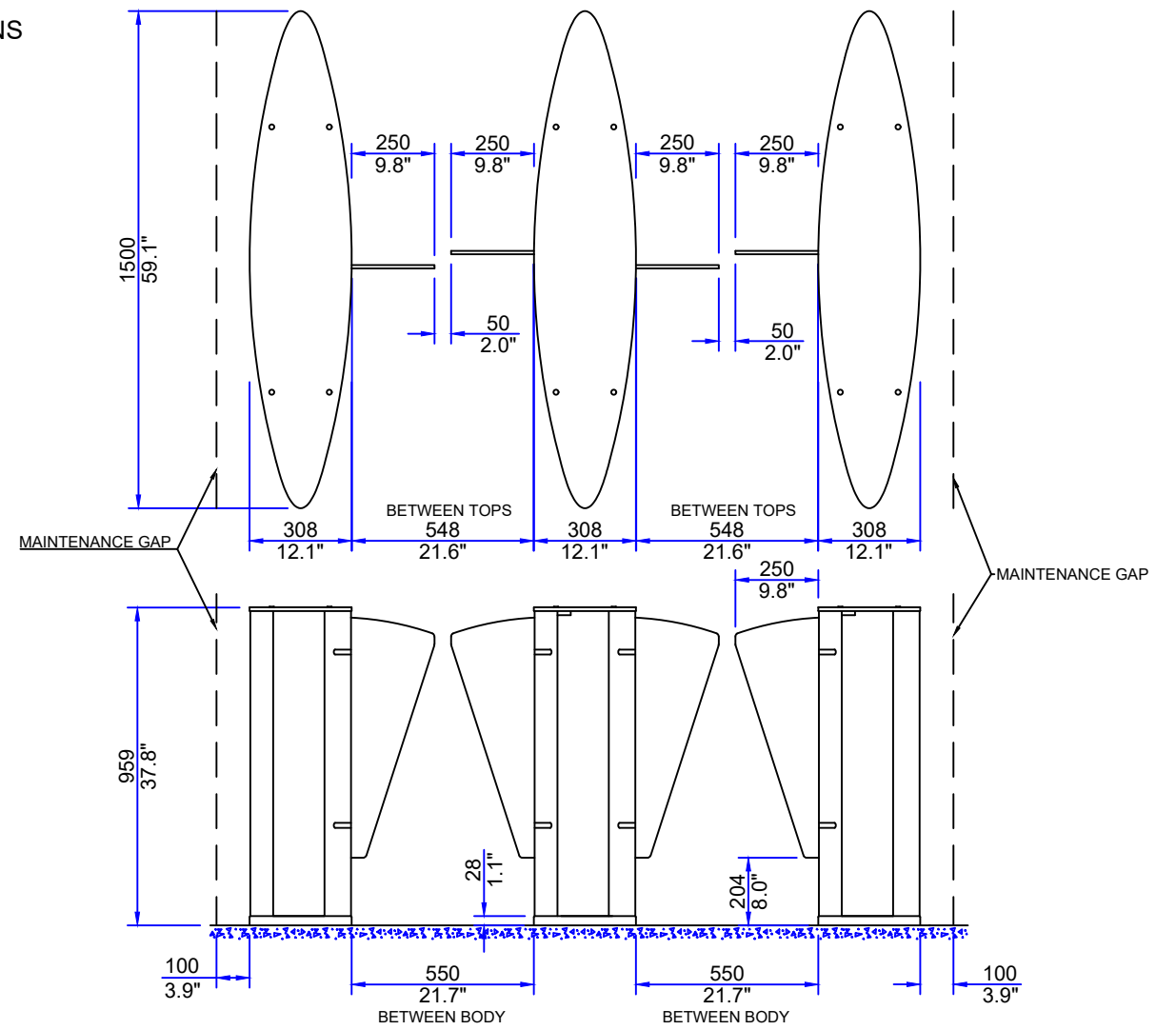

**READER MOUNTING OPTIONS AND LOGO DETAILS**

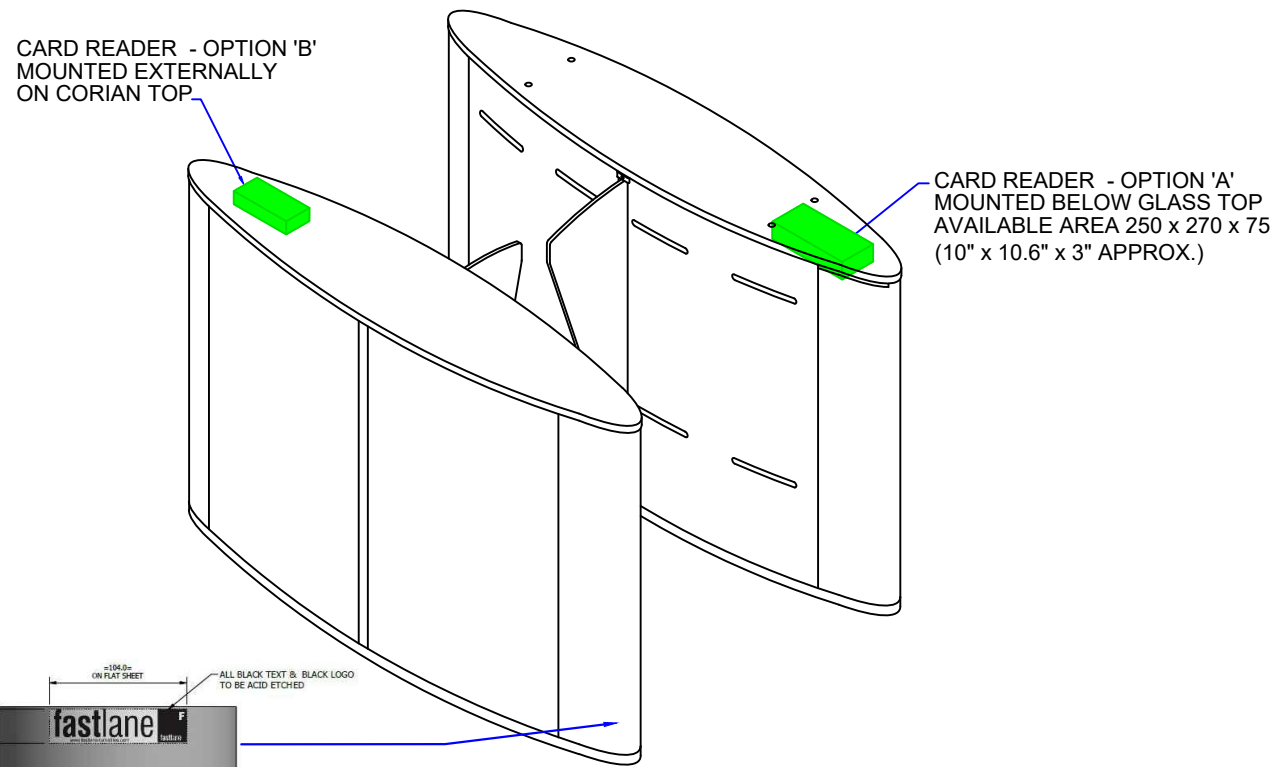

BLACK ACID ETCHED FASTLANE WORD AND LOGO ON ALL BLANK END PANELS (NO END OF LANE INDICATOR END PANELS)

**PEDESTAL FOOTPRINT**

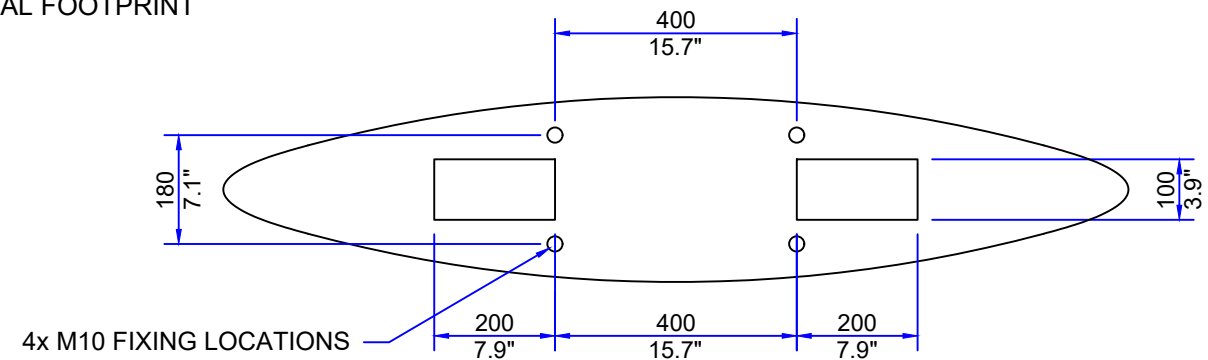

**PRODUCT: GLASSWING COMPACT**

**TITLE: GENERAL INFORMATION**

**DRAWING No: GWCPT\_A6**

FOR SALES INFORMATION ONLY-SUBJECT TO CHANGE  
ALL DIMENSIONS +/-2mm

This document is the copyright of Integrated Design LTD

